

INTRODUCTION

SmarSens is a range of Hohner encoders that give a single encoder the possibility of absolute and incremental signals. Its compact and robust design with numerous communication interfaces available make SmarSens a product that adapts to the real needs of the client. The implementation through an OptoASIC provides a high degree of optoelectronic integration. The range of SmarSens encoders is applicable to a great variety of applications such as wind turbines, elevators, etc.

INCREMENTAL SIGNALS / ABSOLUT SIGNALS 1Vpp

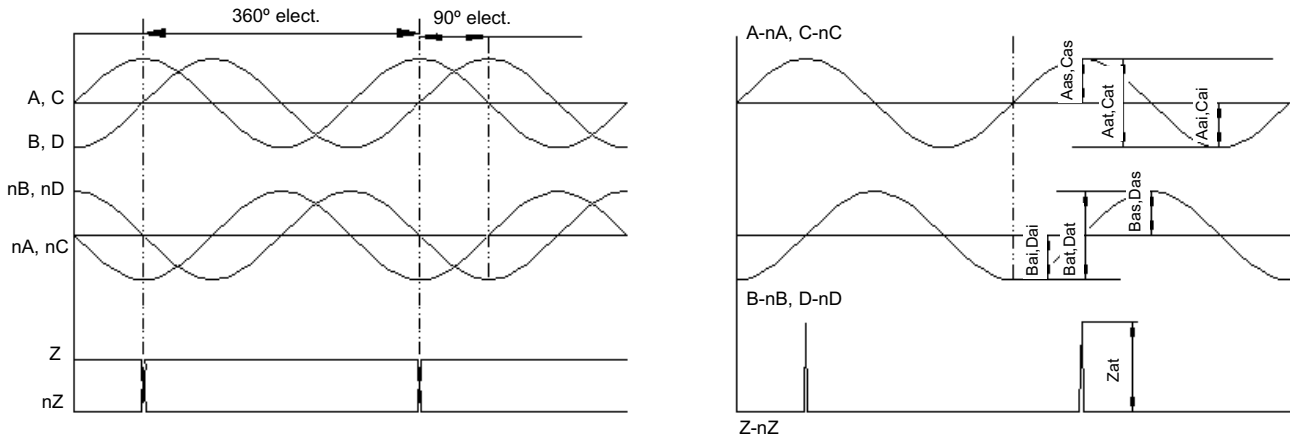

	Amplitude Vpp	Offset / Asymmetry	Amplitude ratio A/B	Phase A to B
A, nA, B, nB C, nC, D, nD	0,5±20%	2,5±10%	-	-
A - nA	1±20%	$ Aas-Aai /(2*(Aas + Aai)) \leq 0.065$	0.8 to 1.25	90°±10°
B - nB	1±20%	$ Bas-Bai /(2*(Bas + Bai)) \leq 0.065$		
C - nC	1±20%	$ Cas-Cai /(2*(Cas + Cai)) \leq 0.065$		
D - nD	1±20%	$ Das-Dai /(2*(Das + Dai)) \leq 0.065$		
Z, nZ	0,5±20%	2,5±10%		
Z - nZ	1±20%			

A: Incremental cosine signal
 B: Incremental sine signal
 C: Absolute cosine signal
 D: Absolute sine signal
 Z: Index signal

Aas, Bas, Cas, Das: Channel A, B, C and D, upper peak voltage amplitude
 Aai, Bai, Cai, Dai: Channel A, B, C and D, lower peak voltage amplitude
 Aat, Bat, Cat, Dat: Channel A, B, C and D, peak to peak voltage amplitude

Sinusoidal outputs are a very useful system to make interpolations that give high resolution to the single turn part. There are incremental signals, A and B, the signal A (cosine) moves in front of B (sine) 90° degrees, and there are absolute signals, C and D, the signal C (cosine) moves in front of D (sine) 90° degrees. The median value of signals A, B, C, D, nA, nB, nC and nD, is 2.5 Vdc. The nA/nC_{inc} signal is 180 degrees from A/COS_{inc}, just nB/nSIN_{inc} is to B/SIN_{inc}, like nC/COS_{abs} and D/SIN_{abs} is to D/SIN_{abs}. The peak to peak of the sinusoids is from 0.4 to 0.6 Vpp. These sine and cosine signals, in the control input, adapt the interpolate signals to 1 Vpp in the A-nA, B-nB, C-nC and D-nD.

SSI INTERFACE

In many cases, the data transmitted from one system to another are exposed to magnetic fields and noise. When using a standard interface like the RS-422, the effects produced by these disruptions are reduced. The SSI "Synchronous Serial Interface" is an industrial output standard that only needs 4 lines to carry out data transmission. This transmission system for absolute encoders provides diverse advantages in comparison to the traditional parallel transmission and asynchronous serial methods:

- Inferior number of components.
- Easy wiring system.
- Data transmission between the encoder and the receiver are controlled by the receivers clock signal.
- High transmission speeds based on distance and data block to be transmitted.

The SSI interface requires a Master (for example, a SSI data acquisition card) and a Slave (the encoder) for communication. The Master generates the CLK and their inverted signals, while the slave generates the DATA and their inverted signals. The communication is one-way. When in idle mode, CLK and DATA have the value "1" (high value). In the data acquisition mode, the Master generates a burst of pulses of the same period T and the Slave will respond with an information bit for each pulse also with a T duration. The CLK and DATA signals are synchronized. To start the transmission, the Master will set the CLK signal to "0" (low value) and then send the pulses. To end the block, the master will maintain during t_m seconds the CLK signal at "1" and then the SLO signal will also become "1". At this point, the Master can interrogate the Slave again. The bits sent during a burst of pulses by the Master are called a block. In the SSI, the standard size of the blocks is 13 or 25 bits, although other sizes are possible.

GENERAL INFORMATION **SmarSens**

In the single-turn mode, the information is transmitted in SSI blocks of at least 13 standard bits. If the single-turn resolution is higher than 13 bits, the block will last n bits, with n being the number of single-turn resolution bits. In the serial delivery, the first bit of data transmitted deals with the most significant bit (MSB) of the block and the last one with the least significant bit (LSB). If the resolution is less than 13 bits, the remaining space up to the 13 bits is filled with zeros. In the SSI1 Figure, you can see the block sent when the resolution is lower than 13 bits and also when it is higher.

In all the SSI blocks, in single-turn, multi-turn, or extended modes, you can add the Alarm and Parity bits activating the relevant configuration bits. By default, these bits are not sent in the block.

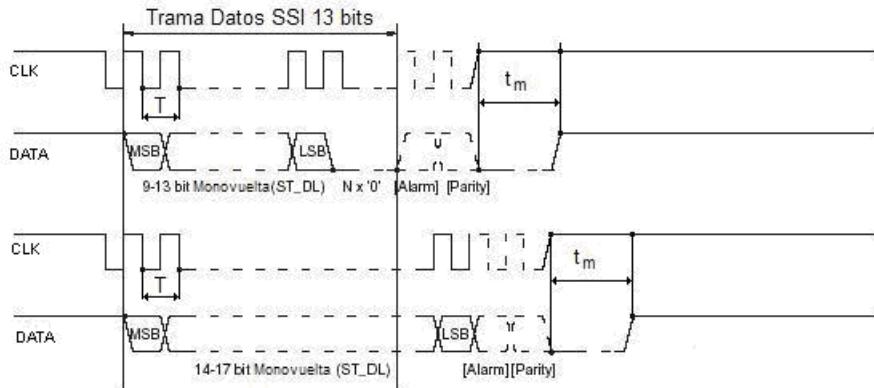

In the multiturn mode, the information is transmitted in standard SSI blocks of 25 bits for singleturn resolutions of less than 14 bits. The 12 bits of the multiturn part are transmitted at the beginning, starting from the most significant bit to the least. Next, the singleturn part bits are transmitted, starting from the most significant bit of the block. If the resolution singleturn is inferior to 13 bits, the bits left over from the block will become zeros. If the singleturn resolution is higher than 13 bits, the size of the block will be $25+(n-13)$ bits, where n is the number of singleturn resolution bits. In the SSI2 figure, you can see the case for a single-turn resolution equal to or less than 13 bits and the case for resolutions higher than 13 singleturn bits.

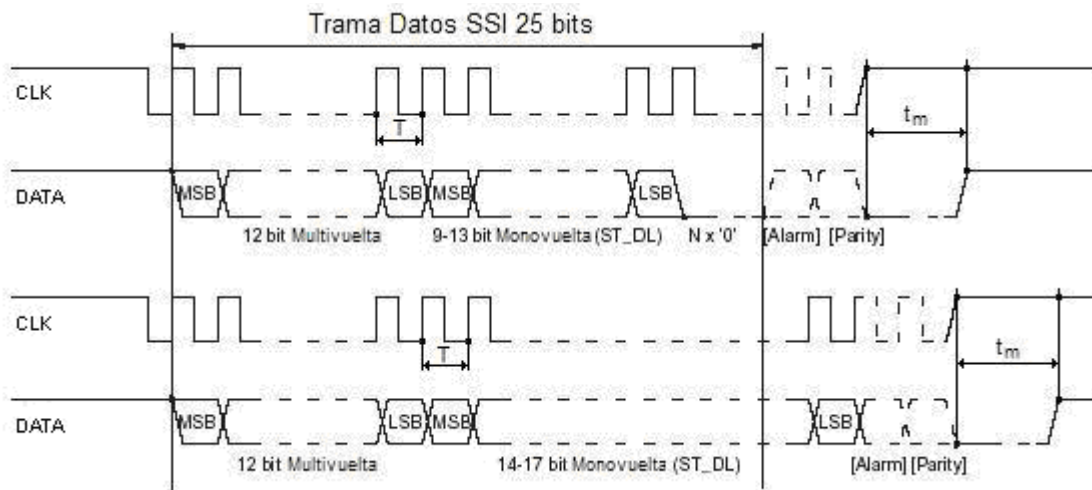

In the SSI extended mode, the length of block is variable, depending on the information sent. First, it transmits the data of the multiturn part, with a variable length of 0 (only single-turn) or 12 bits, from the most significant to the least significant bit. Next, the single-turn part also transmits from the most to the least significant bit. The length can vary depending on the resolution of the part single-turn, from 10 bits to 14 bits. Once transmitted, the least significant bit will send the Alarm and Warning bits. As a method to detect errors in the transmission, a 6 bit CRC will be generated, with the 43h polynomial, of the information processed up to that point (multiturn+singleturn+Alarm+Warning) that will be transmitted after the Warning bit. Next, it will send the information on the sensor temperature encapsulated in 8 bits, and lastly, it will calculate a CRC, with the 4 bits 13h polynomial, that will close the block to transmit, for the 8 bits of sensor temperature data. In the SSI3 figure, you can see the format of the extended SSI block.

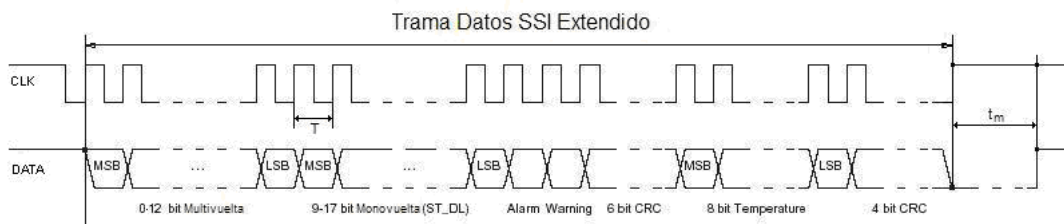

In all cases, the value of T should be from $1\mu s$ to $10\mu s$, and t_m should be higher than $40\mu s$. To correctly operate, you should set up the encoder configuration record to allow SSI-BISS compatibility..

GENERAL INFORMATION **SmarSens**

BISS INTERFACE

This multipoint serial communication standard is open and simple to use. It is similar to the SSI but the control (or master) interacts with the sensors programming the different parameters for each sensor, as well as reading its different status record. For this reason, the BiSS "Bidirectional interface Serial Synchronous", unlike the SSI, is bidirectional. The communication can be from 17KHz to 4MHz frequencies under ideal conditions. For longer sensor-control distances, this frequency gradually diminishes. The maximum number of slaves for each master, like this encoder, that can be connected to a control is four. The BiSS1 figure graphically shows the connection of four slaves with the master. The last slave of the chain has to have the SLI to GND input. Physically, this means that SLI+ should connect to GND and SLI- to 5V. When the encoders interact with other slaves that are not encoders, they must be located on the chain with the lowest identifiers, starting from one. The use of more than one slave with the master implies that the maximum work frequency of the encoder is divided by the number of slaves connected, due to the time that they take in transmitting data to other slaves.

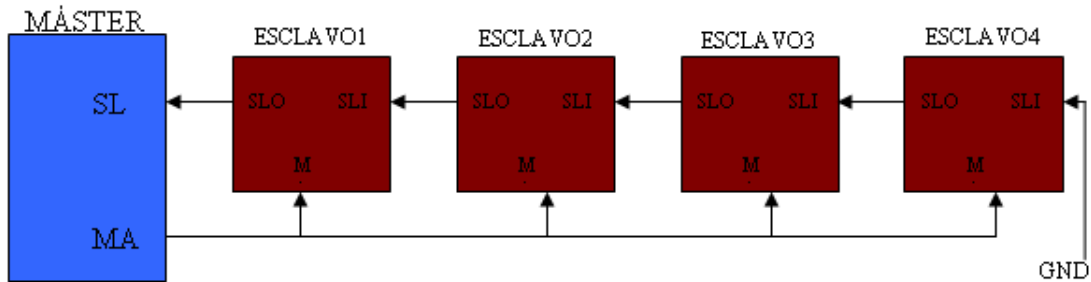

The encoder data reading by the Master (MA) is always one-way, using PWM codification and following the BiSS2 figure format. The Master starts the communication with start bit (start, lowering the signal from "1" to "0"), next, it waits for the encoder's answer, also called slave (SLO) that, before the synchronism signal or clock sent by the master, begins to send data after a start signal. The encoder starts to send data from the most to the least significant bit, and then sends the Error, Alarm and CRC bits of 6 0x43h polynomial generator bits. Lastly, it sends a data bit called a multi-block (MCD). The size of the block depends on the encoder's resolution. After each block, the encoder's position is given

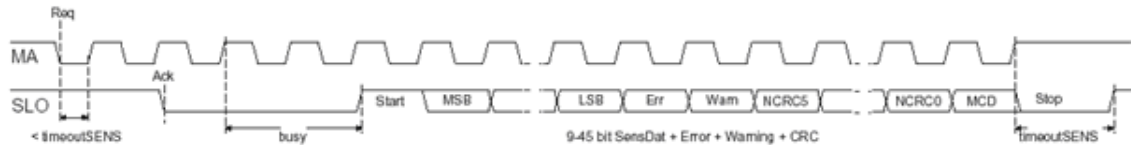

The multi-cycle or multi-block bit does not have any purpose in a single block, but it does when in various blocks, and provides the information on the encoder's temperature.

This temperature is encoded into 8 bits and each bit is transmitted in a different data reading block of the encoder. Also, the entire multi-block cycle includes a start bit to indicate the MCD start, next the 8 bits, the 4 bit CRC with a 0x13h polynomial generator and lastly, a stop bit. Overall, the encoder's temperature reading takes up 16 blocks of data reading. In the BiSS3 figure, you can see the details of this type of transmission.

EXTERNALLY CONFIGURABLE PARAMETERS AND DIAGNOSIS LED (OPTIONAL)

Unscrewing the top of the rear cover, you will find the reset/preset button to position the absolute value of the encoder to a known value.

In the case of a SSI encoder, pushing the button will update the position to 0 (Reset). In the case of a BiSS encoder, when we push the button, we can update the position to any previously programmed value (Preset).

You can also change the direction using the external nDIR input, that when we connected to the GND inverts the encoder's default rotation direction.

The diagnosis LED can also be reached by unscrewing the top. When the encoder and the communication with the master are working correctly, the LED is green. The led is red (in SSI mode) when the communication fails with the master, when the lamps stop working, when the communication fails with the multi-turn part or when the encoder exceeds the recommended work temperature values.

In the BiSS communication mode, the diagnosis LED is configurable with the 0x30h record (error mask) where we can choose what are/is the error/s that we are interested in detecting.

When there is an error in the encoder (diagnosis LED is red), the 8 bit record with direction 0x68h specifies the reason for the error, according to the active bit. The table of errors is :

Bit7	Operation temperate exceeded
Bit6	Error external system sent to NERRR
Bit5	Error in the serial interface
Bit4	Invalid position or data conversion is not ready
Bit3	Configuration error EEPROM interface
Bit2	Error in the pitch codification
Bit1	Error in the multi-turn part
Bit0	Failure in the LED power control

The "Error in the pitch codification" usually causes problems with the disc (breakage, condensation or dirt) or mechanical overload (excess in the rotation speed).

The "Failure in the LED power control" originates when there are problems with heat, dirt, condensation or fatigue.





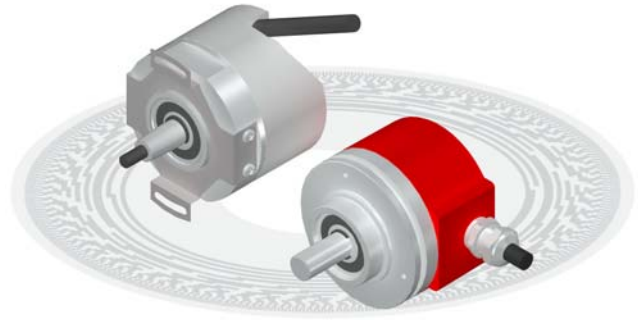

INCREMENTAL AND ABSOLUT ENCODERS

SmarSens

- Absolut and incremental singleturn and multiturn encoder.
- SSI or BISS output absolut interface
- Incremental output signals 1Vpp (sin/cos)
- Solid or hollow shaft
- Absolut resolution up to 131072 position (17 bits) and incrementals up to 2048 sin/cos.
- Radial or axial connection, cable or industrial connector output



OVERVIEW

	Conic shaft	Solid shaft	Blind hollow shaft	Hollow shaft
Singleturn	SMRS 64 	SMRS 10 	SMRS 19 	SMRS 59 
Multiturn		SMRM 10 	SMRM 19 	
Singleturn sincos	SMRS 64S 			

TECHNICAL SPECIFICATION

Housing	Aluminium.
Shaft	Stainless steel.
Bearings	Ballraces.
Bearings lifetime	1x10 ¹⁰ rev.
Maximum number of revolutions permitted mechanically	6000 rpm.
Protection against dust and splashes according to DIN 40050	IP65 or IP54.
Rotor inertia moment	30 gcm ² .
Starting torque 20°C (68°F)	Max. 2 Ncm.
Maximum load permitted on axial shaft	40 N.
Maximum load permitted on radial shaft	60 N.
Weight (singleturn/multiturn)	350/500gr.
Operating temperature range	-10°C a +70°C.
Vibration	100 m/s ² (10Hz...2000Hz).
Shock	1000 m/s ² (6ms).
Consumption max. (singleturn/multiturn)	90mA / 180mA.
Power supply	10..30Vdc / 5Vdc.
Absolut interface	SSI / BISS.
Electrical output (absolut)	RS 422.
Absolut max. frequency (SSI/BISS)	1.5MHz SSI / 4MHz BISS.
Linearity	±1/2 LSB.
Absolut singleturn resolution	10, 12, 13, 14 or 17 bits.
Absolut multiturn resolution	12 bits.
Incremental electrical output	Sin/Cos, 1Vpp.
Incremental singleturn resolution	2048 ppv.
Incremental max.frequency (at.3dB)	200KHz.
Available codes (absolut)	Binary, Gray or configurable.
Direction	External controlled.
nReset/nPreset	By pushbutton.
Diagnosis led	Green = ok, Red = alarm.
Radial or axial connection	Cable (2m) or industrial connector.

SINGLETURN ABSOLUT ENCODER

- Singleturn resolution up to 17 bits
- Protection class IP54 according to DIN 40050
- External diameter 58 mm
- Conic shaft 1:10

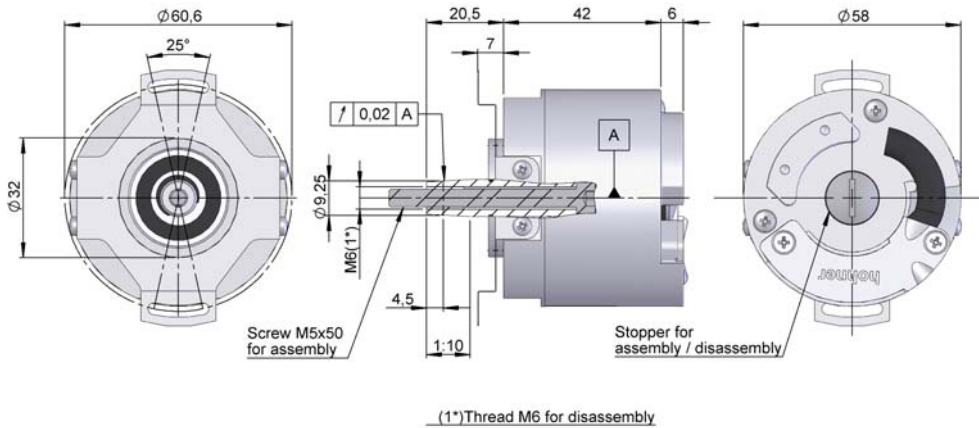

Previous mounting and installation of the encoder is recommended to read the section "TECHNICAL CONSIDERATIONS".

ORDERING CODE

TYPE	SHAFT	ANTIROTATION SYSTEM	CONNECTION	AXIAL RADIAL	INTERFACE	CODE	IP	POWER SUPPLY	PARAMETERS CONFIG.	ABSOLUTE RESOLUTION	SPECIAL CUSTOMER
● ● SMRS64	● 1- Flexible flange ↓ 1- Conic 1:10	● 1- Flexible flange	● 1- Cable	● 0- Helicoidal	● ↓ 1- SSI 2- SSI + SinCos 1Vss 3- BISS 4- BISS + SinCos 1Vss	● 1- Binary CW 2- Binary CCW 3- Gray CW 4- Gray CCW 5- BISS**	● 1- IP54	● ↓ 2- 5 Vdc	● S- Direction L- Diagnosis led	● ● 10- 1024 12- 4096 13- 8192 14- 16384 17- 131072	● ●

Incremental resolution 2048 SinCos.

** Protocol BISS can configurate code, direction and resolution by BUS.

SINGLETURN ABSOLUT ENCODER

- Singleturn resolution up to 17 bits
- Protection class IP65 according to DIN 40050
- External diameter 58 mm
- Solid shaft

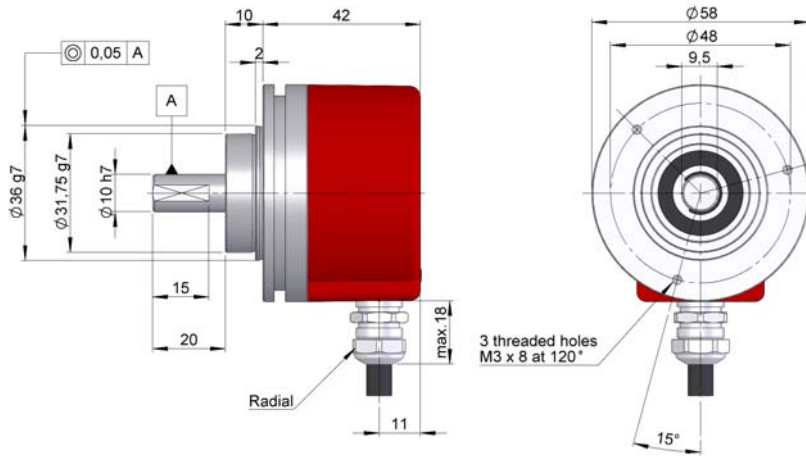

Previous mounting and installation of the encoder is recommended to read the section "TECHNICAL CONSIDERATIONS".

ORDERING CODE

TIPO	SHAFT	FLANGE	CONNECTION	AXIAL RADIAL	INTERFACE	CODE	IP	POWER SUPPLY	CONFIG PARAMETERS	ABSOLUTE RESOLUTION	SPECIAL CUSTOMER
● ● SMRS 10	● 1- $\varnothing 6$ mm 2- $\varnothing 10$ mm	● 1- Without flange 2- 90.1002 3- 90.1003 4- 90.1004 5- 90.1005 6- 90.1006	● 1- Cable 3- 90.9512 7- 90.9517	● 1- Axial 2- Radial	● 1- SSI 2- SSI + SinCos 1Vss 3- BISS 4- BSS + SinCos 1Vss	● 1- Binary CW 2- Binary CCW 3- Gray CW 4- Gray CCW 5- BISS**	● 1- IP65	● 1- 10...30 Vdc 2- 5 Vdc	● S- Direction	● ● ● ● ● 10- 1024 12- 4096 13- 8192 14- 16384 17- 131072	● ● ●

Incremental resolution 2048 SinCos.

** Protocol BISS can configurate code, direction and resolution by BUS.

SINGLETURN ABSOLUT ENCODER

- Singleturn resolution up to 17 bits
- Protection class IP54 according to DIN 40050
- External diameter 58 mm
- Blind hollow shaft

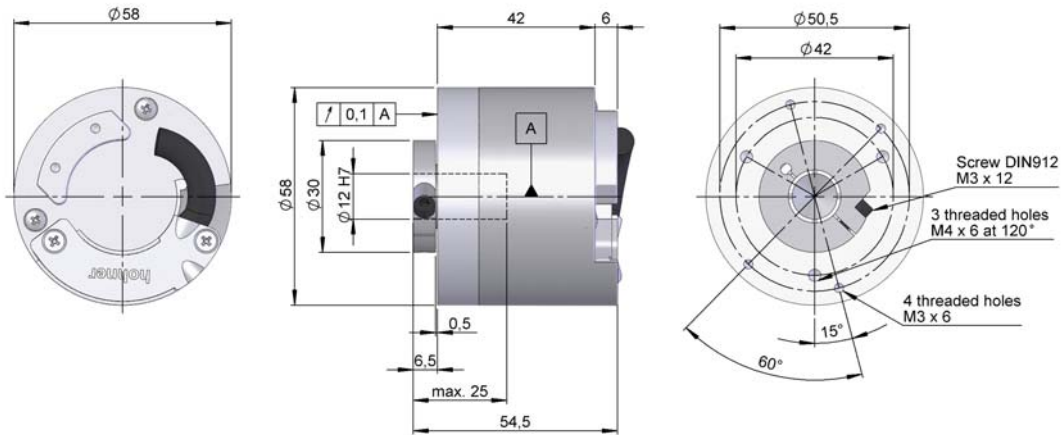

Previous mounting and installation of the encoder is recommended to read the section "TECHNICAL CONSIDERATIONS".

ORDERING CODE

TYPE	SERIE	SHAFT	FLANGE	CONNECTION	AXIAL RADIAL	INTERFACE	CODE	IP	POWER SUPPLY	CONFIG. PARAMETERS	RESOLUTION	SPECIAL CUSTOMER
● ●	19	●	●	●	●	●	●	●	●	●	● ● ● ●	● ●
SMRS- Singleturn		3- $\varnothing 12$ mm 4- $\varnothing 10$ mm	1- None	0- Helical 1- Cable		1- SSI 2- SSI + SinCos 1Vss 3- BISS 4- BISS + SinCos 1Vss	1- Binary CW 2- Binary CCW 3- Gray CW 4- Gray CCW 5- BISS**	1- IP54	1- 10...30 Vdc 2- 5 VDC	S- Direction	10- 1024 12- 4096 13- 8192 14- 16384 17- 131072	

Incremental resolution 2048 SinCos.

** Protocol BISS can configurate code, direction and resolution by BUS.

SINGLETURN ABSOLUT ENCODER

- Singleturn resolution up to 17 bits
- Protection class IP54 according to DIN 40050
- External diameter 58 mm
- Hollow shaft

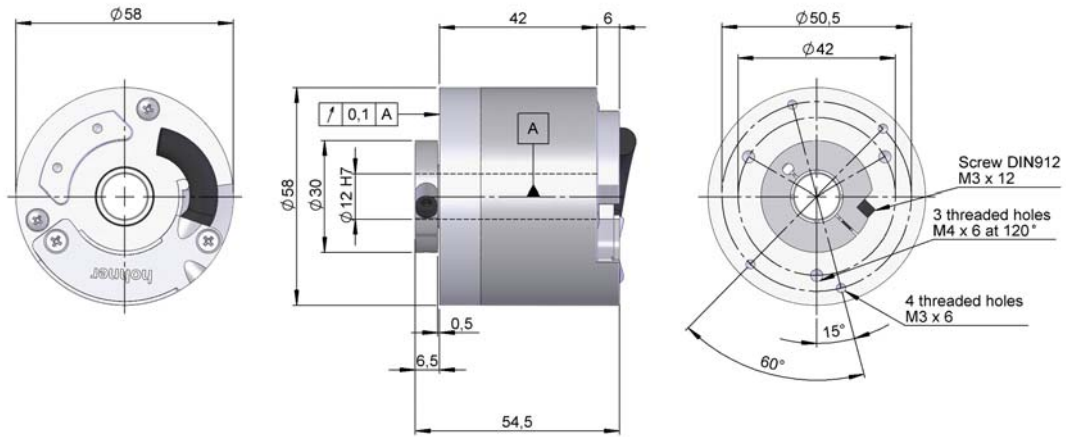

Previous mounting and installation of the encoder is recommended to read the section "TECHNICAL CONSIDERATIONS".

ORDERING CODE

TYPE	SERIE	HOLLOW SHAFT	FLANGE	CONNECTION	AXIAL RADIAL	INTERFACE	CODE	IP	POWER SUPPLY	RESOLUTION	SPECIAL CUSTOMER
● ●	59	●	●	●	●	●	●	●	●	● ●	● ●
SMRS- Singleturn		3- $\phi 12$ mm 4- $\phi 10$ mm	1- None	1- Cable	0- Helical	1- SSI 2- SSI + SinCos 1Vss 3- BISS 4- BISS + SinCos 1Vss	1- Binary CW 2- Binary CCW 3- Gray CW 4- Gray CCW 5- BISS**	1- IP54	1- 10...30 Vdc 2- 5 Vdc	10- 1024 12- 4096 13- 8192 14- 16384 17- 131072	

Incremental resolution 2048 SinCos.

** Protocol BISS can configurate code, direction and resolution by BUS.

MULTITURN ABSOLUT ENCODER

- Multiturn resolution up to 26 bits
- Protection class IP65 according to DIN 40050
- External diameter 58 mm
- Solid shaft

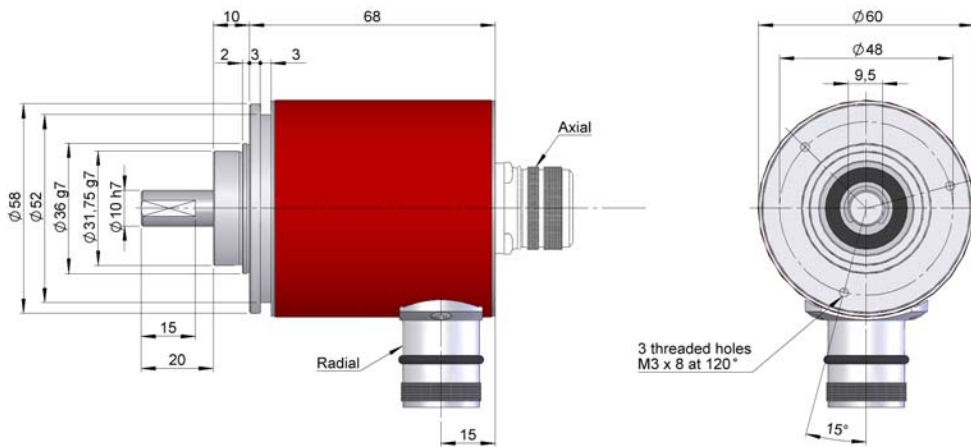

Previous mounting and installation of the encoder is recommended to read the section "TECHNICAL CONSIDERATIONS".

ORDERING CODE

TYPE	SERIE	SHAFT	FLANGE	CONNECTIO N	AXIAL RADIAL	INTERFACE	CODE	IP	POWER SUPPLY OUTPUT	SINGLETURN / MULTITURN RESOLUTION	SPECIAL CUSTOMER
● ● ● 10 SMRM - Multiturn		●	●	●	●	●	●	●	●	● ● ● ●	● ●
		1- Ø10 mm 2- Ø6 mm	1-None 2- 90.1002 3- 90.1003 4- 90.1004 5- 90.1005 6- 90.1006	1- Cable 3- 90.9512 7- 90.9517	1- Axial 2- Radial	1- SSI 2- SSI + SinCos 1Vss 3- BiSS 4- BiSS + SinCos 1Vss	1- Binary CW 2- Binary CCW 3- Gray CW 4- Gray CCW 5- BiSS**	1- IP65	1- 10...30 Vdc 2- 5 VDC	1212- 4096 / 4096 1312- 8192 / 4096 1412- 16384 / 4096	

MULTITURN ABSOLUT ENCODER

- Multiturn resolution up to 26 bits
- Protection class IP65 according to DIN 40050
- External diameter 58 mm
- Blind hollow shaft

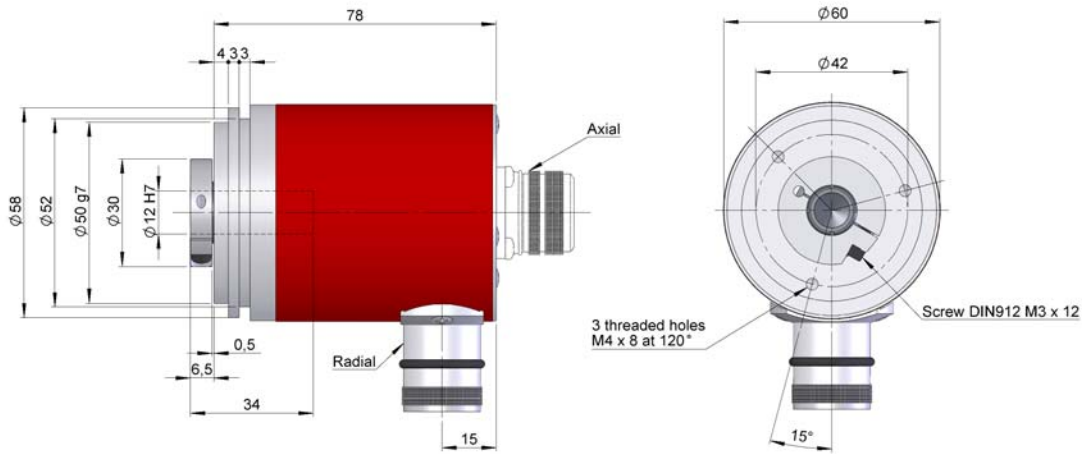
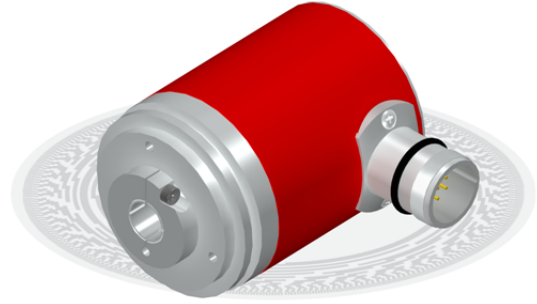

Previous mounting and installation of the encoder is recommended to read the section "TECHNICAL CONSIDERATIONS".

ORDERING CODE

TYPE	SERIE	SHAFT	FLANGE	CONNEC-TION	AXIAL RADIAL	INTERFACE	CODE	IP	POWER SUPPLY OUTPUT	SINGLETURN / MULTITURN RESOLUTION	SPECIAL CUSTOMER
● ● ●	19	●	●	●	●	●	●	●	●	● ● ● ●	● ●
SMRM - Multiturn		3- Ø 12 mm 4- Ø 10 mm	1- None	1- Cable 3- 90.9512 7- 90.9517	1- Axial 2- Radial	1- SSI 2- SSI + SinCos 1Vss 3- BISS 4- BISS + SinCos 1Vss	1- Binary CW 2- Binary CCW 3- Gray CW 4- Gray CCW 5- BISS**	1- IP65	1- 10...30 Vdc 2- 5 Vdc	1212- 4096 / 4096 1312- 8192 / 4096 1412- 16384 / 4096	

SINGLETURN ABSOLUT AND INCREMENTAL ENCODER

- Incremental resolution 2048 SinCos
- Absolut resolution 1 SinCos
- Protection class IP54 according to DIN 40050
- External diameter 58 mm
- Conic shaft 1:10

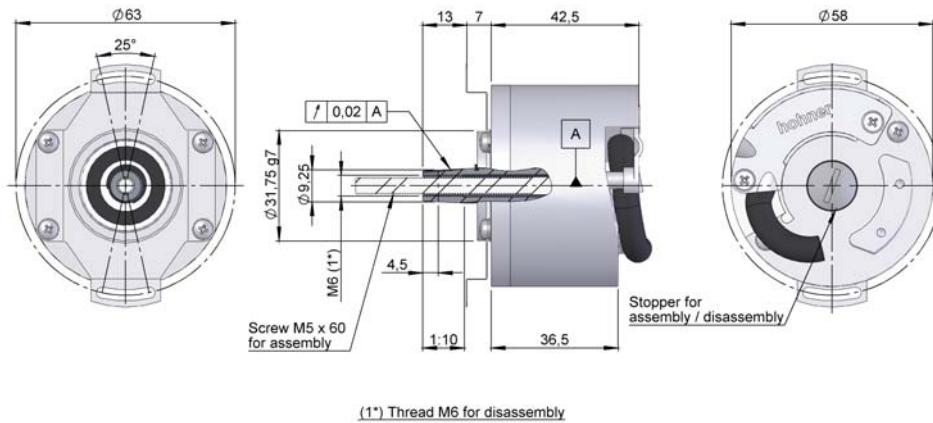

Previous mounting and installation of the encoder is recommended to read the section "TECHNICAL CONSIDERATIONS".

ORDERING CODE

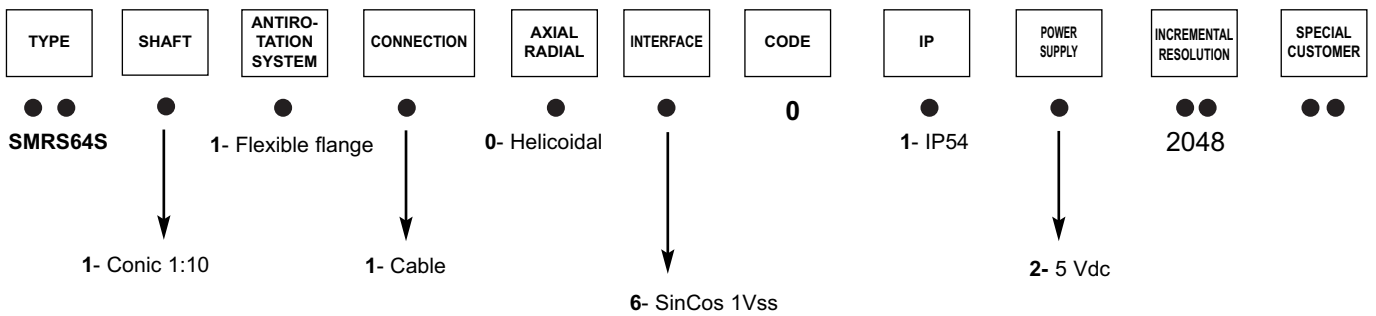

Absolut resolution : 1 SinCos

CONNECTORS AND CONNECTION

CONNECTION



	Cable 6x2x0.14 BISS	Cable 3x2x0.14+2x0.34 SSI	Connector 90.9512 BISS	Connector 90.9512 SSI	Connector 17 pin M23
GND	Brown	Black	1	1	10
Vcc	White	Red	8	2	7
SLO+ / DATA+	Rose	Yellow	2	3	14
SLO- / DATA-	Grey	Green	7	4	17
MA+ / CLOCK+	Yellow	Brown	3	5	8
MA- / CLOCK-	Green	Blue	6	6	9
SLI+	-	-	-	-	1
SLI-	-	-	-	-	4
nDIR	Red-Blue	Grey	9	9	2
A/COS	Red	-	10	10	15
B/SIN	Black	-	4	7	12
nA/nCOS	Blue	-	12	12	16
nB/nSIN	Violet	-	5	8	13
Screen	Screen	Screen	11	11	11

CONNECTION SMRS64S



Cable 6x2x0.14

POWER SUPPLY

Gnd	White
Vcc	Brown

INCREMENTAL SIGNALS

A+	Green
A-	Yellow
B+	Blue
B-	Red
Z+	Grey-Rose
Z-	Red-Blue

ABSOLUT SIGNALS

C+	Grey
C-	Rose
D+	Black
D-	Violet